



Patent Analysis – the Technical Intelligence professional's adjustable spanner

Bob Stembridge
Customer Relationships Manager
Thomson Scientific

Agenda

- Why patents are useful as technical intelligence
- Semantics & linguistic variation
- The importance of classification
- Some ground rules
- Three tips:
 - Classification discontinuity
 - Normalisation
 - Sorting the wheat from the chaff
- Conclusions

Why patents are useful as technical intelligence

- Publicly available detailed technical information:
 - Usually the first source
 - In up to 80% of cases, may be the only source
 - Full and practical descriptions
- Licensed industrial espionage
 - Attributed
 - Technical detail
- Identify and monitor competitors & key inventors
- Monitor research trends
- Identify potential infringers/partners/licensors

Semantics

- A rose by any other name would smell as sweet...*Shakespeare, Romeo & Juliet*



- One man's spanner is another man's monkey wrench
- We are divided by a common language

George Bernard Shaw



CLASS 7 COMPOUND TOOLS

138 WRENCH

139 .Adjustable, e.g., monkey wrench, pipe wrench, etc.



SECTION B – PERFORMING OPERATIONS; TRANSPORTING

B 25 HAND TOOLS; PORTABLE POWER-DRIVEN TOOLS; HANDLES FOR HAND IMPLEMENTS; WORKSHOP EQUIPMENT; |
B 25 B TOOLS OR BENCH DEVICES NOT OTHERWISE PROVIDED FOR, FOR FASTENING, CONNECTING, DISENGAGING, OR

13/ 00 **Spanners; Wrenches** (hand-driven gear-operated B25B 17/00; impact wrenches B25B 19/00; portable power-driven B25B 21/ together or separating metal parts B23P 19/00)

- 13/ 02 . with rigid jaws (B25B 13/46, B25B 13/48 take precedence)
- 13/ 04 . . of ring jaw type
- 13/ 06 . . of socket type
- 13/ 08 . . of open jaw type
- 13/ 10 . with adjustable jaws (B25B 13/46, B25B 13/48 take precedence)
- 13/ 12 . . the jaws being slidable
- 13/ 14 . . . by rack and pinion, worm or gear
- 13/ 16 . . . by screw or nut

United States Patent [19]

Jenq-Shyong

[11] **Patent Number:** **4,572,037**

[45] **Date of Patent:** **Feb. 25, 1986**

[54] **MONKEY WRENCH**

[76] **Inventor:** Ke Jenq-Shyong, No. 397, Sec. 2 Tan Hsing Rd., Tan Yiang Village, Tan-Tzu Hsiang, Taichung Hsien, Taiwan

[21] **Appl. No.:** 590,857

[22] **Filed:** Mar. 19, 1984

[51] **Int. Cl.⁴** B25B 13/12

[52] **U.S. Cl.** 81/126

[58] **Field of Search** 81/126, 132, 133

[56] **References Cited**

U.S. PATENT DOCUMENTS

1,664,932	4/1928	Juricinec	81/126
2,536,463	1/1951	Ratliff	81/126
2,636,412	4/1953	Houdesheldt	81/126

2,703,503	3/1955	Hairston	81/126
3,988,952	11/1976	Dirks	81/126

Primary Examiner—James G. Smith

[57] **ABSTRACT**

An improved monkey wrench comprising a handle having two prongs each having a space through hole, a main body rotatably disposed between the prongs of the handle, a spring loaded jaw mounted at the main body in the way such that it may be slightly moved towards or away from the main body, a movable jaw movably mounted into the main body, a push member slidably mounted on the top of said main body and fixedly attached to the movable jaw, and an actuating member mounted at the center of the main body and fastened to the handle.

2 Claims, 5 Drawing Figures

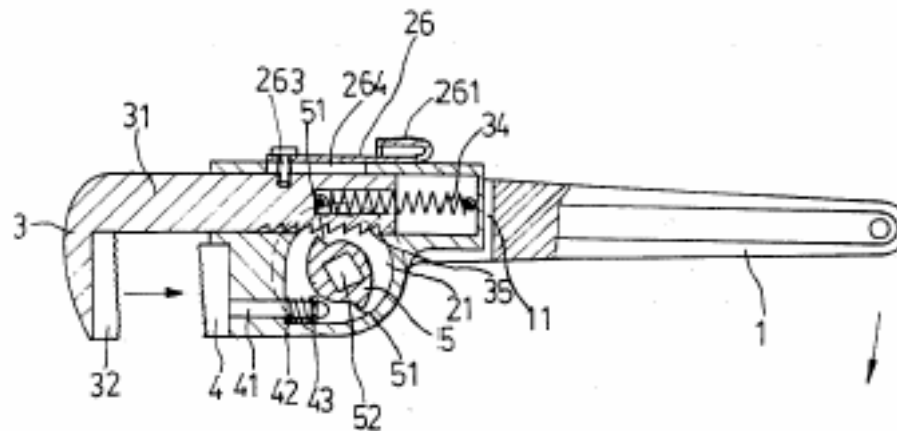

(12) INTERNATIONAL APPLICATION PUBLISHED UNDER THE PATENT COOPERATION TREATY (PCT)

(19) World Intellectual Property Organization
International Bureau



(43) International Publication Date
6 March 2003 (06.03.2003)

PCT

(10) International Publication Number
WO 03/018262 A1

- (51) International Patent Classification: **B25B 13/20**, 13/22
- (21) International Application Number: PCT/DGHO/03078
- (22) International Filing Date: 22 August 2002 (22.08.2002)
- (25) Filing Language: English
- (26) Publication Language: English
- (30) Priority Data:
0120003.6 24 August 2001 (24.08.2001) GB
- (71) Applicant (for all designated States except US): **HTM PRODUCTS LTD.** (GB); Globe House, Farnham Road, Haslemere GU28 9BA (GB).
- (72) Inventor; and
(73) Inventor/Applicant (for US only): **HARRISON, Ian, Austin** (GB/US); Basement Flat, 27 Charles Road, St. Leonards-On-Sea, TN38 0QE1 (GB).
- (74) Agent: **LECKEY, David, Herbert, Frank B. Dehn & Co.**, 179 Queen Victoria Street, London EC4V 4HL (GB).
- (81) Designated States (national): AE, AG, AL, AM, AT (utility model), AU, AZ, BA, BB, BG, BR, BY, BZ, CA, CH, CN, CO, CR, CU, CZ (utility model), DE (utility model), DK, DM, DZ, EC, EE (utility model), EG, ES, FI (utility model), FR, GB, GD, GE, GH, GM, HR, HU, ID, IL, IN, IS, JP, KH, KG, KP, KR, KZ, LC, LK, LR, LS, LU, LV, MA, MD, MG, MK, MN, MW, MX, MZ, NO, NZ, OM, PL, PT, RO, RU, SD, SE, SG, SI, SK (utility model), SL, TJ, TM, TN, TR, TT, TZ, UA, UG, US, UZ, VC, VN, YU, ZA, ZM, ZW.
- (84) Designated States (regional): ARIPO patent (GH, GM, KE, LS, MW, MZ, SD, SL, SZ, TZ, UG, ZM, ZW), Eurasian patent (AM, AZ, BY, KG, KZ, MD, RU, TJ, TM), European patent (AT, BE, BG, CH, CY, CZ, DE, DK, EE, ES, FI, FR, GB, GR, HU, IT, LU, MC, NL, PT, SE, SK, TR), OAPI patent (BF, BJ, CF, CG, CI, CM, GA, GN, GQ, GW, ML, MR, NE, SN, TD, TG).
- Published**
— with international search report
- For two-letter codes and other abbreviations, refer to the "Guidance Notes on Codes and Abbreviations" appearing at the beginning of each regular issue of the PCT Gazette.*

(54) Title: **ADJUSTABLE SPANNER**

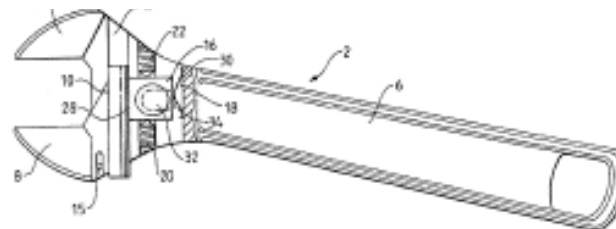

(57) Abstract: The present invention relates to an adjustable spanner (2) having a first fixed jaw (4) and a second moveable jaw (8). The second jaw (8) can be locked in fixed relation to the first jaw (4) by a locking means (16). This locking means (16) is moveable between a first position in which the second jaw (8) is fixed in relation to the first jaw (4) and a second position in which the second jaw (8) is permitted to move with respect to the first jaw (4).

WO 03/018262 A1

- Schraubenschlüssel German
- clé réglable French
- llave de tuercas ajustable Spanish
- 調節可能なスパナー Japanese
- 조정가능한 스패너 Korean
- 活絡扳子 Chinese
- регулируемый гаечный ключ Russian

① BUNDESREPUBLIK DEUTSCHLAND
 ② Offenlegungsschrift DE 197 25 624 A 1
 ③ Int. Cl.®: B 25 B 13/10
 B 25 B 13/14
 ④ Aktenzeichen: 197 25 624.4
 ⑤ Anmeldetag: 17. 6. 97
 ⑥ Offenlegungstag: 2. 1. 98
 DEUTSCHES PATENTAMT
 DE 197 25 624 A 1

⑦ Unionspriorität:
 8-180275 20.06.96 JP
 8-18927 30.01.97 JP
 ⑧ Anmelder:
 Top Kogyo Co., Ltd., Sanjo, Niigata, JP
 ⑨ Vertreter:
 HOFFMANN · EITLE, 81625 München

⑩ Erfinder:
 Watanabe, Kiyochi, Sanjo, Niigata, JP

54 Schraubenschlüssel

Anzeiger für die zu befestigende Mutter durch die andere Mutter behindert wird, und bei dem ein offener Anzeigerstand in einem bestimmten Bereich eingegriffen werden kann. Der Schraubenschlüssel weist folgende Elemente auf: einen Schraubenschlüsselkörper, in dem eine Mutterantriebsfläche (2a) an einem Endabschnitt eines Griffs (1) vorgesehen ist, wobei eine winklige Öffnung (3) in durchstehender Art und Weise in einem unteren Abschnitt der Mutterantriebsfläche (2a) ausgebildet ist, und wobei ein offenes Schreckenfenster (4) fortlaufend unter der winkligen Öffnung (3) ausgebildet ist; ein gleitbares Klausenelement (b), in dem Zahnstangenzähne (5) an einem hinteren Abschnitt eines im wesentlichen L-förmigen Querschnitts angeordnet sind, das eine sich bewegende Antriebsfläche (2b) aufweist, die zu der Mutterantriebsfläche (2a) gerichtet ist; und einen Schraubenschlüsselkörper (c), der drehbar um einen Schraubenschlüssel (5) vorgesehen ist, der in dem offenen Schreckenfenster (4) des Schraubenschlüsselkörpers (a) vorgesehen ist und veranlaßt wird, mit den Zahnstangenzähnen (5) des gleitbaren Klausenelements (b) in Eingriff zu kommen; wobei der gleitbare Klausenelement (b) gleitbar in die winklige Öffnung (3) des Schraubenschlüsselkörpers (a) eingeführt ist, und der ...

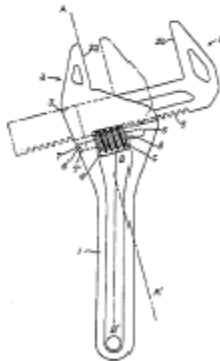

Die folgenden Angaben sind den vom Anmelder eingereichten Unterlagen entnommen. DRUCKSCHLEIFEREI 15. 97 702 981 005 10/93

(12) 日本国特許庁 (J.P.P.) (12) 公開特許公報 (A) (11) 特許出願公開番号
 特開平11-207645
 (43) 公開日 平成11年(1999)5月3日

(51) Int.Cl.® 分類記号 P :
 B 25 B 13/02 B 25 B 13/02 H
 13/10 13/10 B

審査請求 未請求 請求項の数 3 O L (全 7 項)

(21) 出願番号 特願平10-14243 (71) 出願人 599011950
 豊田 隆弘
 岐阜県各務原市引加坂町3丁目230番地
 (22) 出願日 平成10年(1998)1月27日 (72) 発明者 豊田 隆弘
 岐阜県各務原市藤原大塚町4丁目10番地の
 10
 (74) 代理人 弁護士 豊田 隆直

(54) 【発明の名称】 自在スパナ

(57) 【要約】
 【課題】 種々の被回転部材の径に対応できるとともに、被回転部材のね返り又はねじ込作業を容易かつ短時間で行うことができる自在スパナを提供する。
 【解決手段】 自在スパナ10を構成する本体20は、一体的に設けられた固定部24を有し、固定部24と対向する位置には、スライド可能な可動部30が設けられている。押圧部材60は、把持部11と一体的に回転するように取付けられ、本体20を所定方向に回転させる際には本体20に対して回転不能に支持され、可動部30の挿入片32を押圧するようになっている。また、この押圧部材60は、本体20を反対方向に回転させるときに本体20に対して回転可能に支持されるようになっている。被回転部材は、固定部24と可動部30との間に挟持され、ね返り又はねじ込されるようになっている。

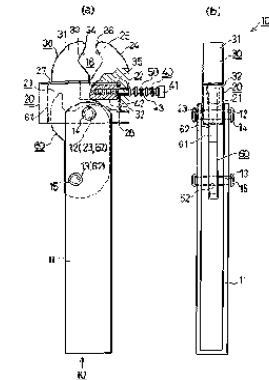

AE=Assignee Name + Code DCR=DCR Number

SMF=Standardized Molecular Formula
 SD=Structure Description
 SUD=Substance Descriptors
 CIA=Compound Name, All
 SYII=Compound Name, Preferred + Synonym
 CHS=Compound Name, Systematic
 DCN=Derwent Compound Number
 DRII=Derwent Registry Number
 RII=Ring Index Number

SEARCH

CLEAR FORM

Session History

HIDE HISTORY

[To Top](#)

To combine searches from the Session History, enter the number of the search and the required operator, e.g. (#1 AND #2) NOT #3, then click the Combined Search button.

COMBINED SEARCH

Set	Compounds	Patents	Combination	Search History	SAVE HISTORY / ALERTING	OPEN HISTORY	Delete Sets
#5	-	55	-	[Patent: #2 not #1] <i>Database(s)=Chemical Section, Electrical and Electronic Section, Engineering Section; Timespan=1966-2005</i>			<input type="checkbox"/>
#3	-	1,200	-	[Patent: #1 or #2] <i>Database(s)=Chemical Section, Electrical and Electronic Section, Engineering Section; Timespan=1966-2005</i>			<input type="checkbox"/>
#2	-	177	-	[Patent: IP=(b25b-013/16)] <i>Database(s)=Chemical Section, Electrical and Electronic Section, Engineering Section; Timespan=1966-2005</i>			<input type="checkbox"/>
#1	-	1,145	-	[Patent: TS=(adjustable and (spanner or wrench))] <i>Database(s)=Chemical Section, Electrical and Electronic Section, Engineering Section; Timespan=1966-2005</i>			<input type="checkbox"/>

Field Tag Key

SELECT ALL

DELETE [Acceptable Use Policy](#)Copyright © 2005 [Thomson Derwent](#) and Thomson ISI. [FEEDBACK](#)

Abstract:

NOVELTY - The tool has an operation end (20) connected to an end of a handle (10), which is a curve and a flat plate. A twist portion (13) is located at a mediate portion between two sections (11, 12) of the handle. One section has a wide surface which is located on a plane that is perpendicular to a plane in which a surface of the operation end is located. A user applies force at the wide surface to rotate the operation end.

USE - Hand tool e.g. wrench and spanner.

ADVANTAGE - The user applies the force at the wide surface to rotate the operation end, and hence the user's hand suffers less pressure, thus tolerating the pressure applied to the hand.

DESCRIPTION OF DRAWING(S) - The drawing shows a top view of a hand tool.

Handle (10)

Sections (11, 12)

Twist portion (13)

Operation end (20)

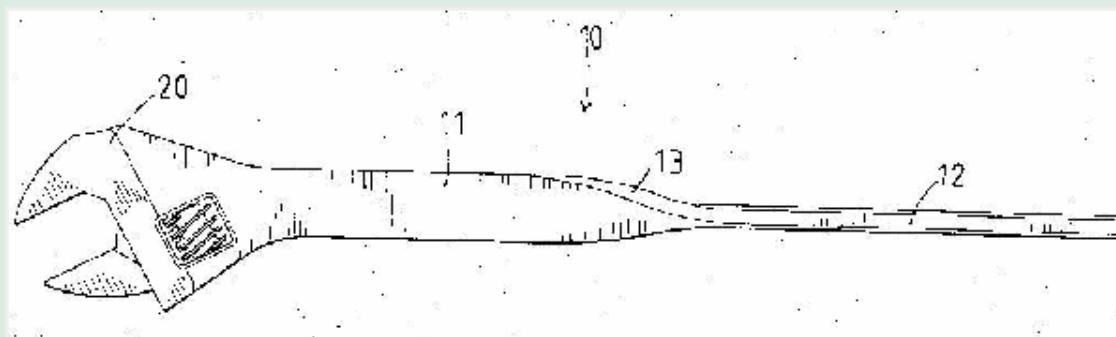
Drawing:**International Patent Classification:**

B25B-013/16

Some ground rules

- Documents vs inventions
- Application vs grant
- Publication vs application (dates = 18 month rule)

Analysis of patenting activity over time – publication vs. priority date:

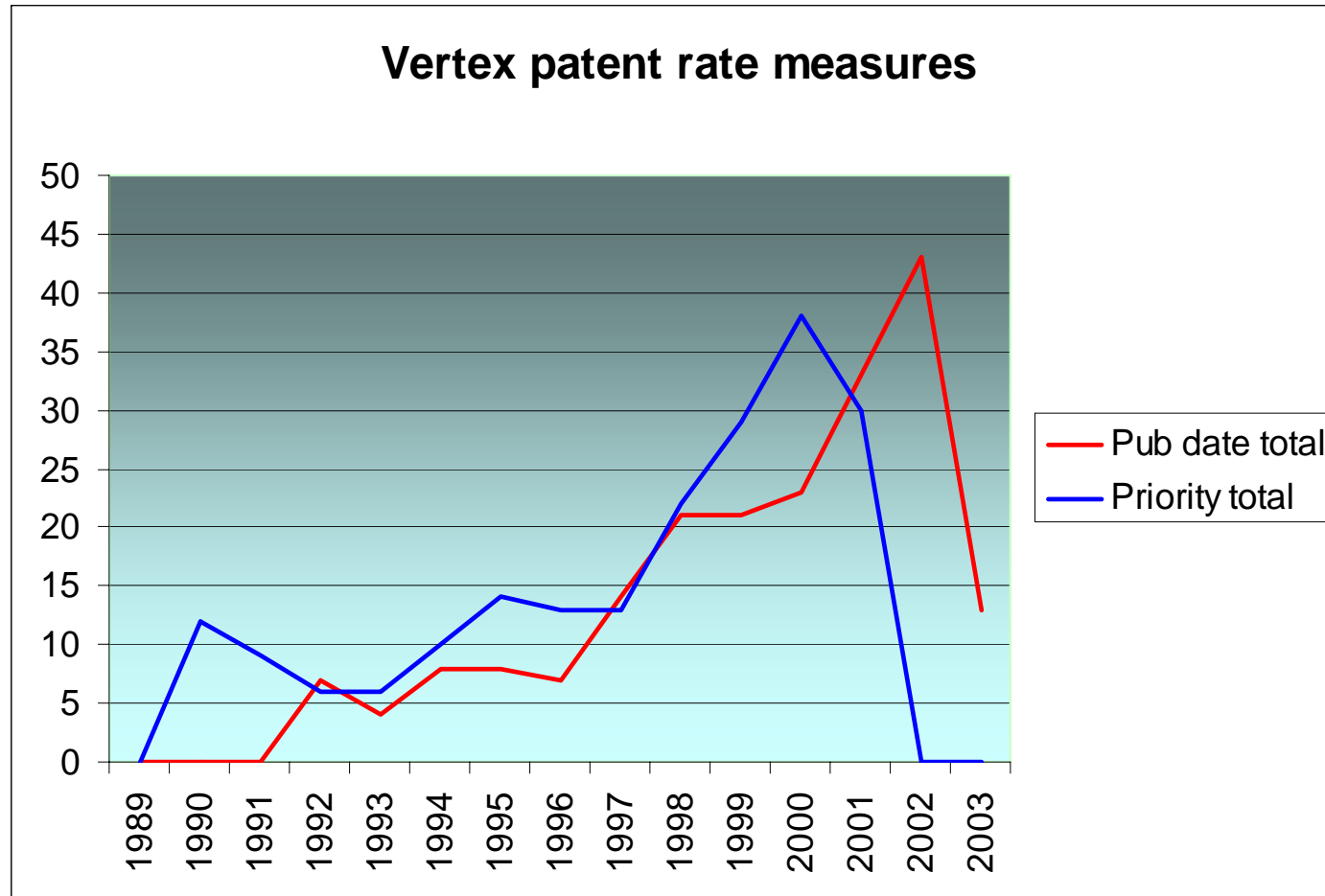

Analysis of patenting activity over time – publication vs. priority date:

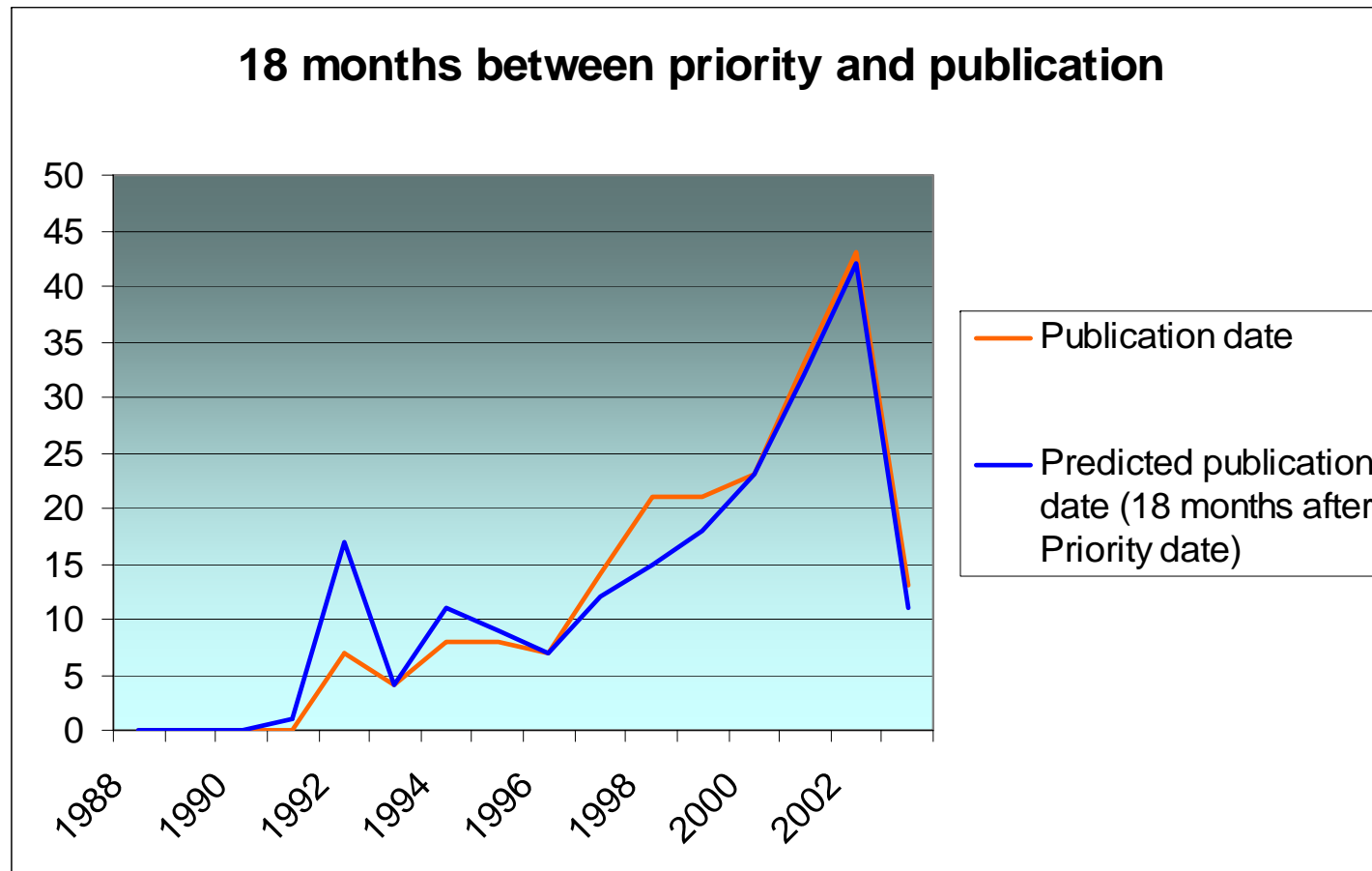

Three tips

- Tip one – Classification discontinuity
- Tip two – Normalisation
- Tip three – Sorting the wheat from the chaff

Three tips

- **Tip one – Classification discontinuity**

- Tip two – Normalisation

- Tip three – Sorting the wheat from the chaff

The curious case of the dog in the night...

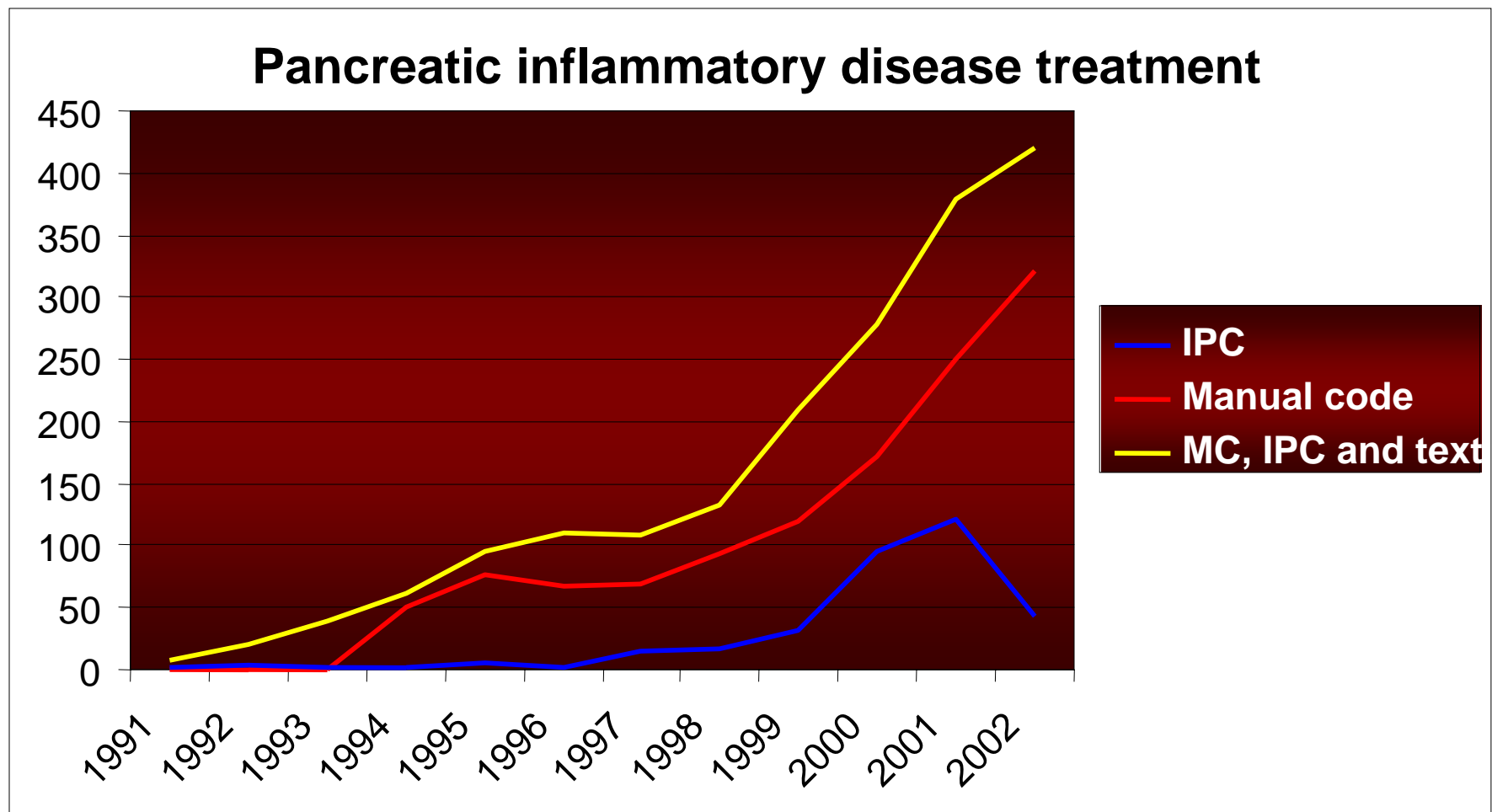

Three tips

- Tip one – Classification discontinuity

- Tip two – Normalisation**

- Tip three – Sorting the wheat from the chaff

Technology portfolio analysis:

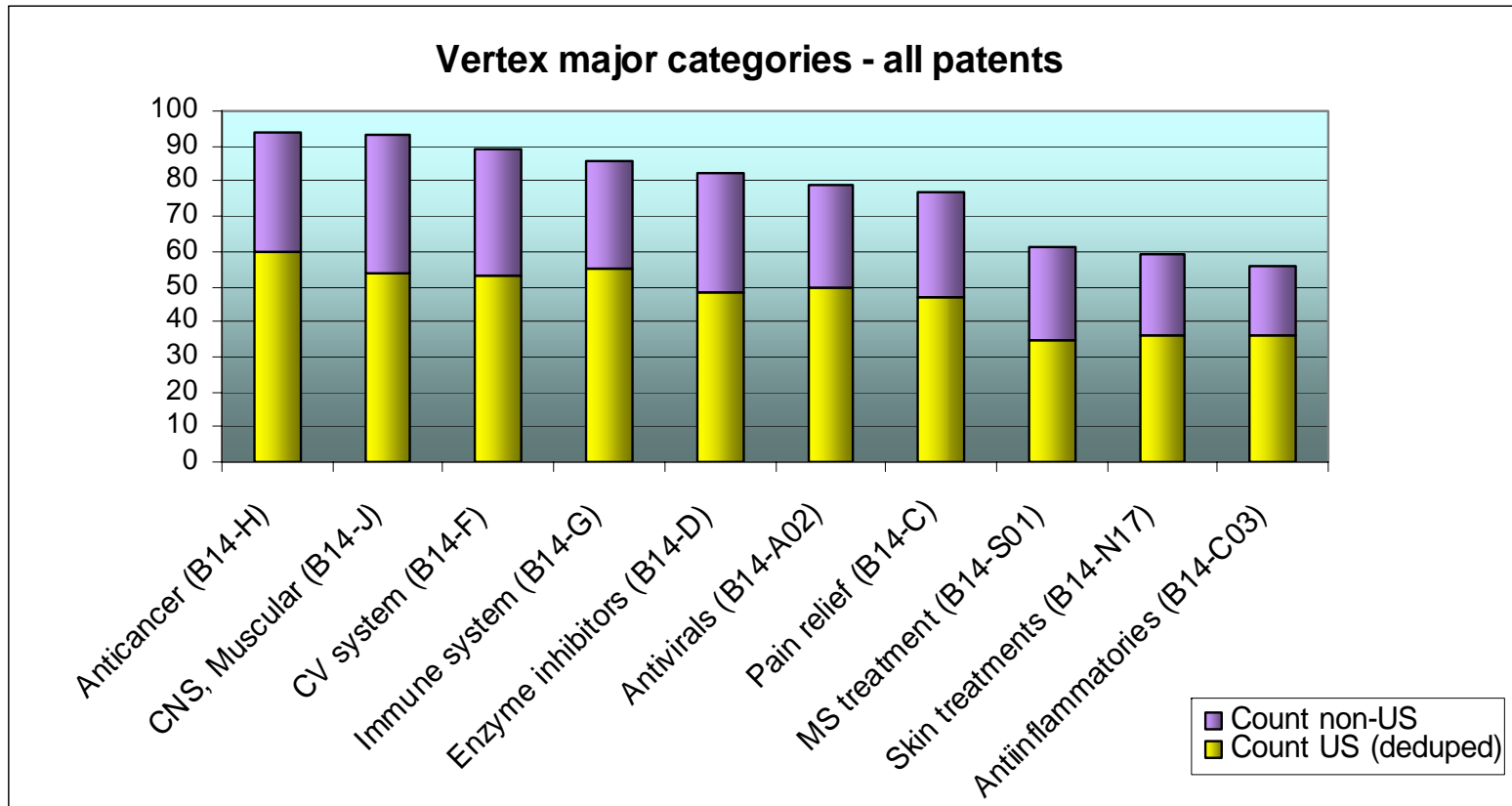

Normalisation:

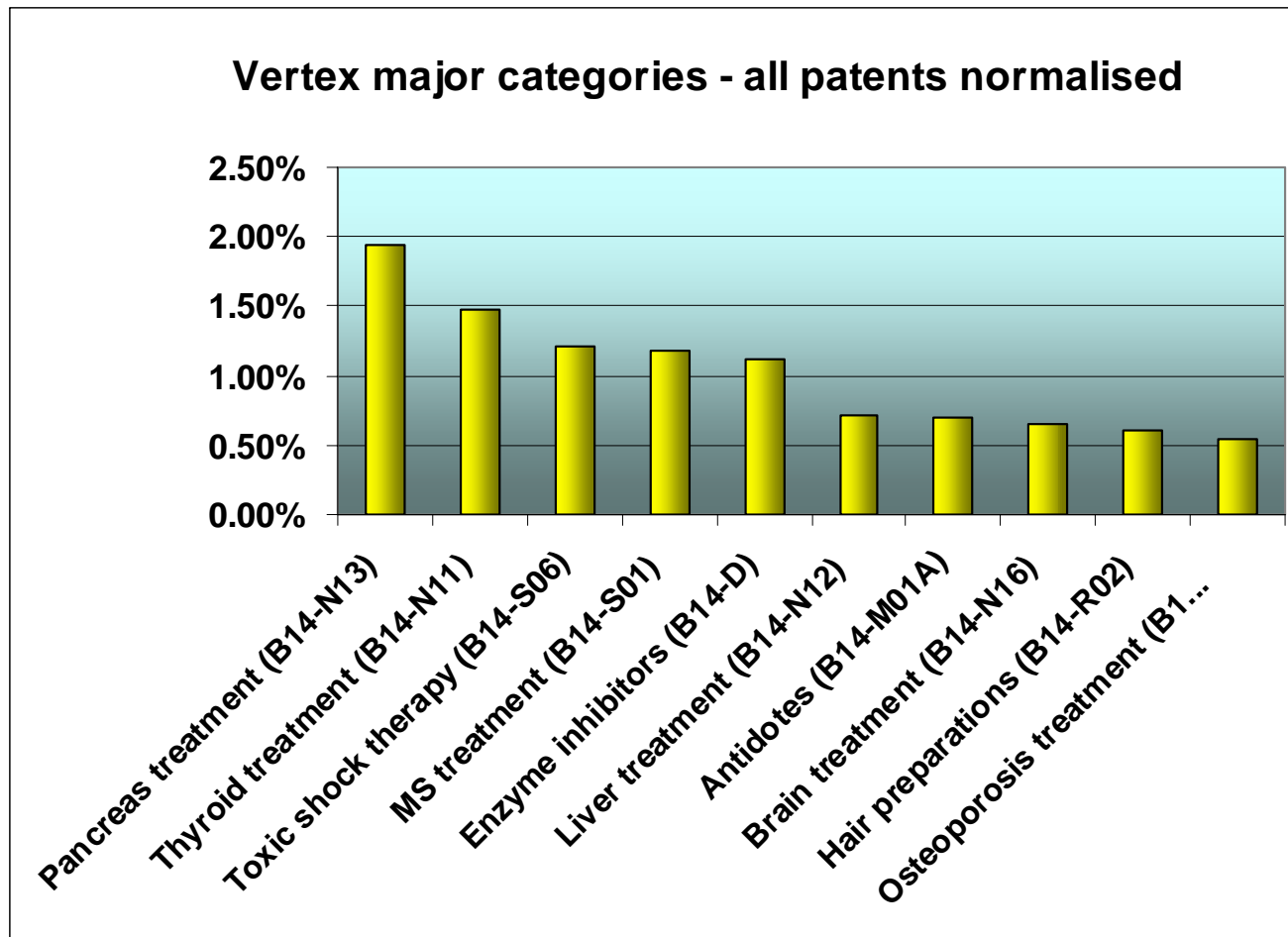

Three tips

- Tip one – Classification discontinuity
- Tip two – Normalisation

•Tip three – Sorting the wheat from the chaff

- Geographic spread
- Forward citation frequency
- Legal status

Geographic spread

Basic Patent number	Pub date	Number of authorities	Topic
WO9405639	17/03/1994	22	New sulphonamide derivs.
WO9407858	14/04/1994	19	New 1-(2-oxo:acetyl)-piperidine-2-carboxylic acid
WO9817679	30/04/1998	18	New peptide serine protease inhibitors
WO9636630	21/11/1996	18	New tetralin derivs.
WO9633187	24/10/1996	18	New sulphonamide derivs.
WO9615101	23/05/1996	18	New amino acid derivs.
EP623606	09/11/1994	17	New peptidic ketone(s)
WO9933815	08/07/1999	16	New sulfonamide prodrugs
WO9633184	24/10/1996	16	New sulphonamide derivs.
WO9535308	28/12/1995	16	Interleukin-1 beta converting enzyme inhibitor
WO9202617	20/02/1992	16	Use of crosslinked immobilised enzyme crystals
WO9827098	25/06/1998	15	New substituted nitrogen containing heterocycle
WO9820891	22/05/1998	15	New pharmaceutical composition containing a ne
WO9740028	30/10/1997	15	Inhibiting inosine-5'-mono:phosphate dehydrogena
WO9712855	10/04/1997	15	Butyrate prodrugs having good bioavailability
WO9958502	18/11/1999	14	Heterocyclic inhibitors of P38

Forward citation frequency

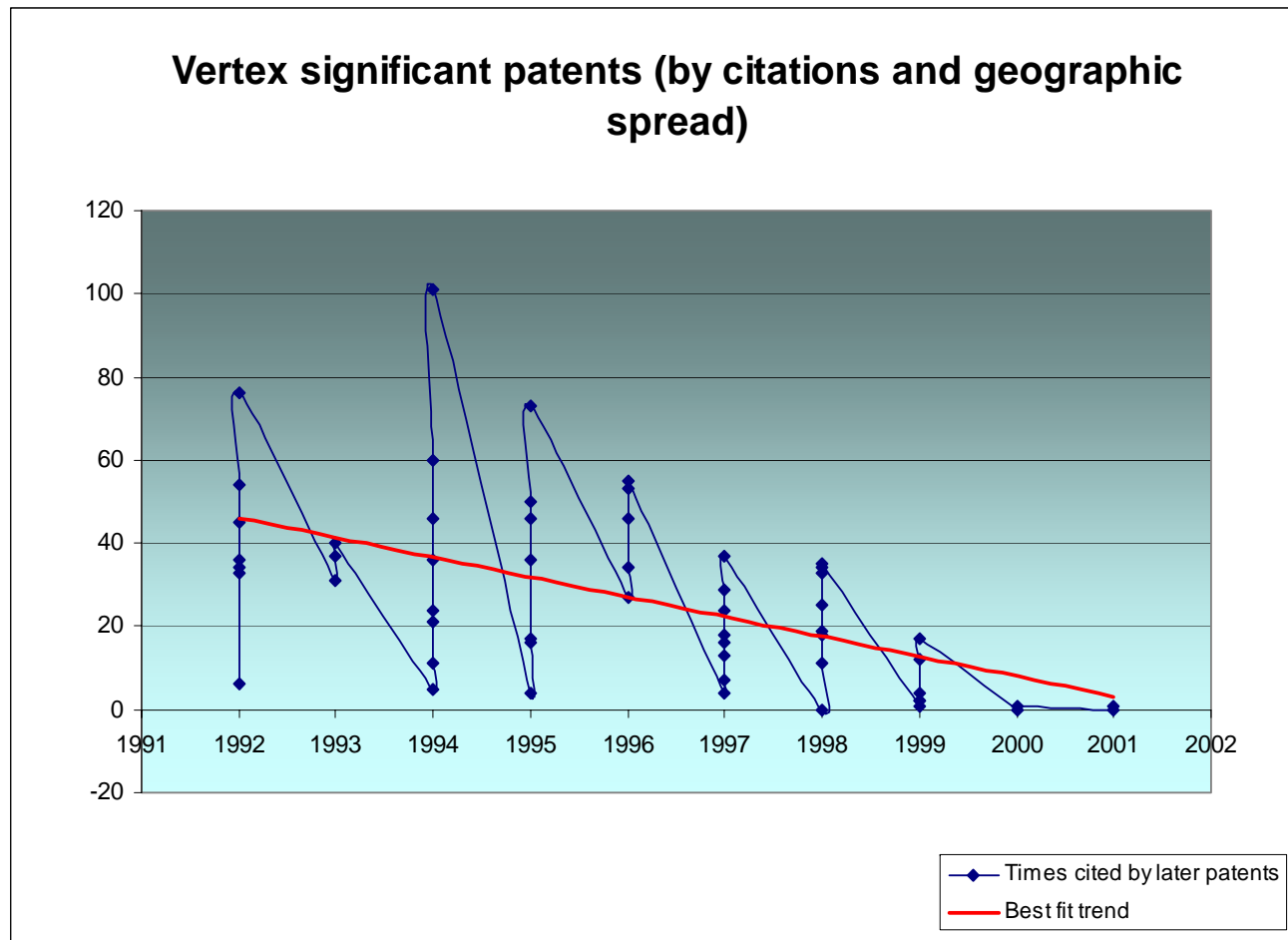

Conclusions

- Data source and search strategy is key
- Understanding of codes and classifications is important
- Useful techniques:
 - Normalisation
 - Averaging counts over time
- Qualification
 - Geographic spread
 - Citation frequency
 - Legal status
- Patent analysis can be valuable for highlighting areas for further study and corroboration



. . . . Thank you